

## Quiet Island

### Quiet Island: Rigid-Damped Tripods

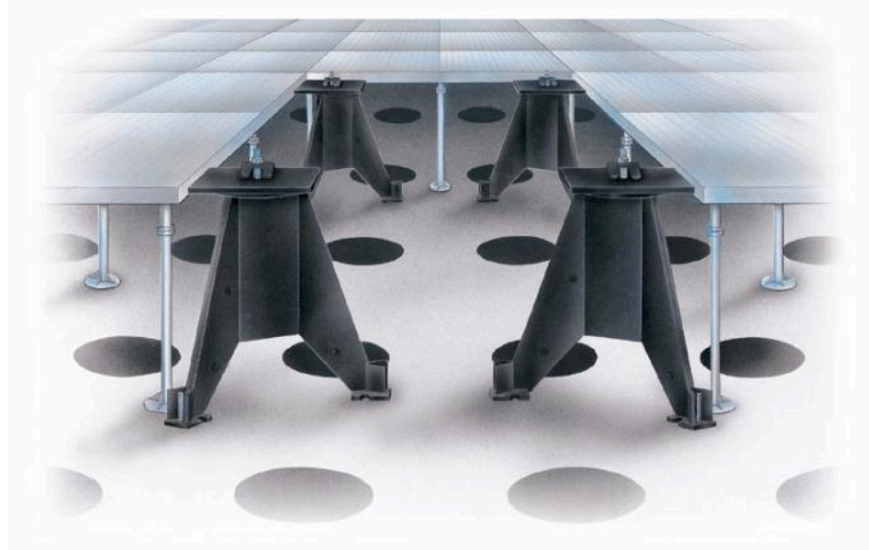

Figure 1, *Rigid Damped Tripods*

### Introduction

The rigid-damped tripod is designed to bridge the space from a cleanroom sub-floor to a tool foot at the height of the raised floor with a rigid, non-resonant, damped structure. Provisions are designed in to allow for sub-floor attachment, tool attachment and clearance of sub-floor holes as well as utilities.

### Setup Procedure

- Step 1** Place the tripod on the sub-floor with its centerline coaxial with the tool-foot to be supported.

The tripod may be rotated about its axis to clear holes (“pop-outs”) in the sub-floor, conduits, cables, etc.



**Note** If the pop-outs in the sub-floor cannot be avoided, a plate to bridge the pop-outs may be required to support the base of the tripod. Contact TMC for design assistance.

**Step 2** Adjust the **5/8-11 x 3 inch** socket set screws at the three feet of the tripod to bring the top, square surface of the tripod flush with the raised floor.

The tripod has a  $\pm 1$  inch vertical travel range using an Allen key.

**Step 3** Loosen the **5/8-11 x 1 inch** flat head socket cap screw on the square top plate of the tripod.

Rotate the top plate so that it is square with the raised floor, then re-tighten the screw.

**Step 4** Rigidly attach tripod to the sub-floor using one or both of the following methods.



Figure 2, *Rigid Damped Tripod*

**Anchor bolts** Two slots **0.63 inch** are provided in each of the three tripod base-plates. After hard-shimming between the tripod base-plates and sub-floor, insert **1/2 inch** anchor bolts in the sub-floor to align with the base-plate slots and fasten with a **1/2 inch** nut.

**Grouting** Whether or not anchor bolts are used, the tripod feet may be “grouted” to the sub-floor.

Using a form approximately **2 inches** tall, grout the feet to the sub-floor using “Rockite,” “Sikadur” or an equivalent compound.

**Step 5** Three **3/8-16** tapped holes are provided in the tripod top plate. Tool feet may be anchored to the tripod using this tapped hole pattern and an appropriate fixture (depending on the size and shape of the equipment tool foot).

## Individual Rigid Stands

### Rigid Support Post

- Floor heights: **6 inches to 24 inches**
- Post heights: Variable

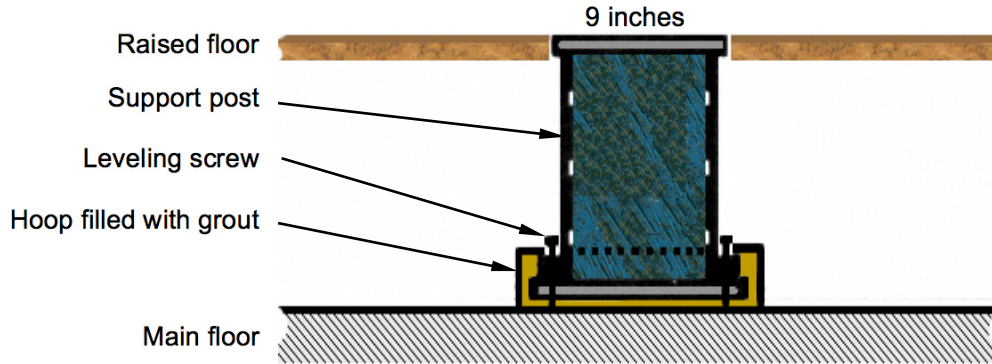

Figure 3, *Rigid support post, short floors*

### Rigid Support Post

- Floor heights: **18 inches to 24 inches**
- Post heights: Variable

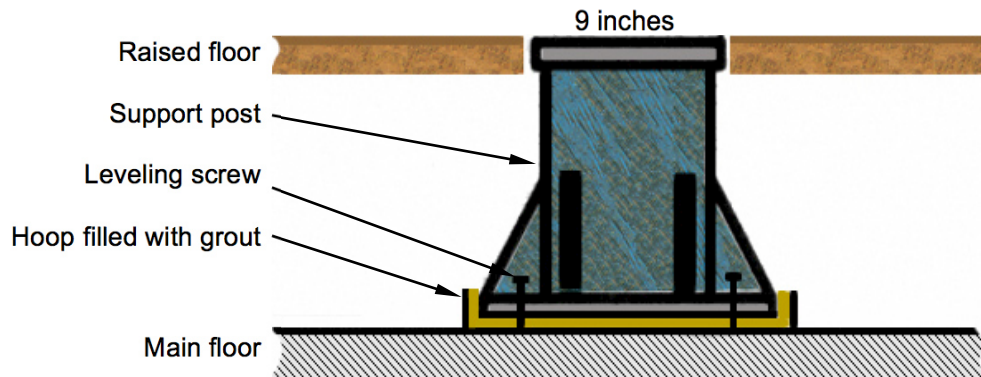

Figure 4, *Rigid support post*

### Rigid Damped Tripod

- Raised floor heights: **18 inches to 24 inches**
- Tripod heights: **11 inches, 17 inches & 23 inches**

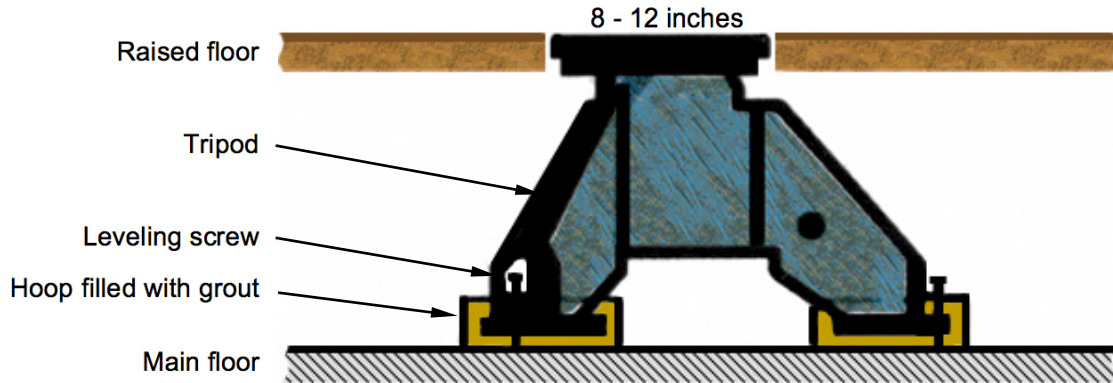

Figure 5, *Rigid damped tripod*

### Rigid Damped Tripod

- Raised floor heights: **36 inches, 1 meter, 48 inches**
- Tripod heights: **35 1/4 inches, 38 5/8 inches, 47 1/4 inches**

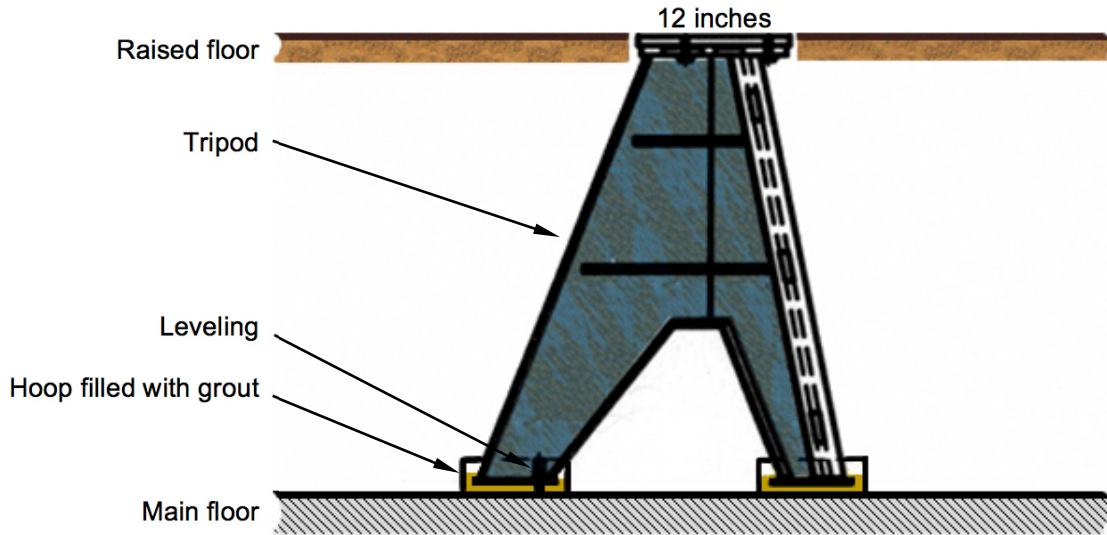

Figure 6, *Flat top rigid tripod*

## Quiet Island: Sub-floor Platform & Stands

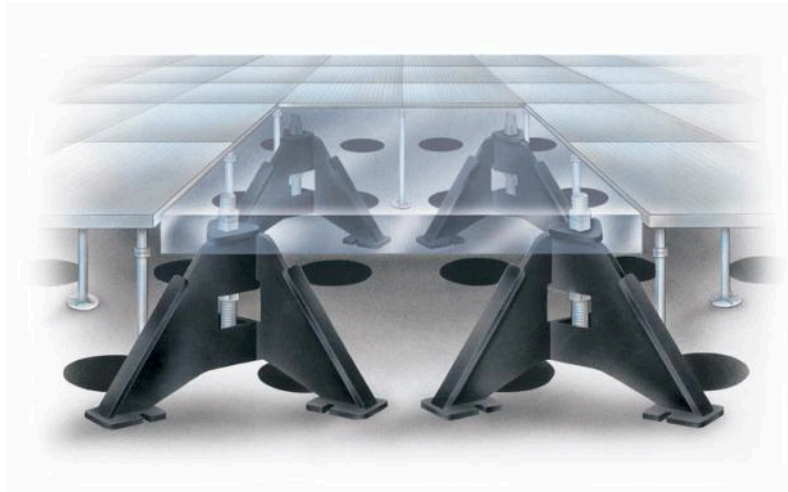

Figure 1, *Quiet Island Sub-floor Platform & Stands*

### Introduction

#### Support platforms

Platform is made in a wide range of sizes to suit most equipment that is best mounted on solid "tool pedestals" rather than on the raised cleanroom floor.

Platforms might be used for vibration control or load support reasons.

#### Common platform thicknesses:

- **4 inch** - larger or more sensitive tools
- **2-1/2 inch** - less sensitive or special height applications.

#### Jack Stands

A range of robust, adjustable jack stands are made to suit various raised floor heights. Most stands are **8 inches** square post type with baseplates for shorter floor heights, or tripod type with greater lateral stability for higher floors.

These instructions cover the general case of most simple platform setups with a regular array of support stands.

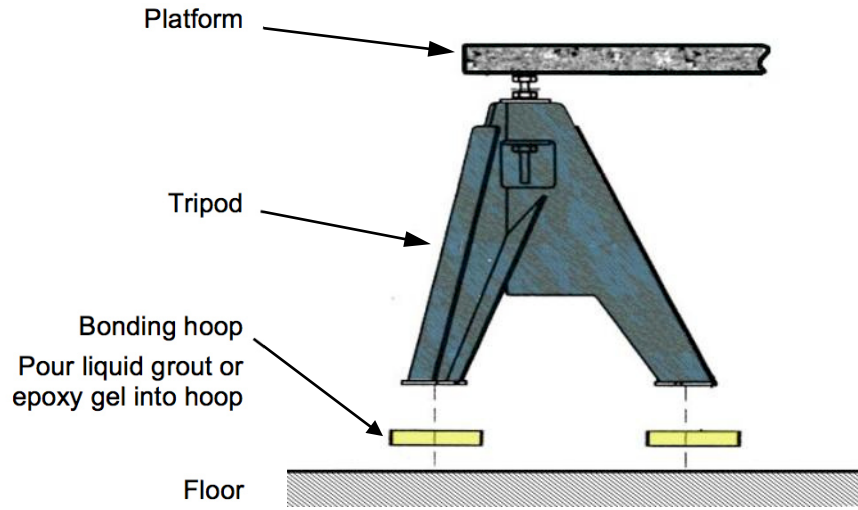

Figure 2, Tripod leveling floor stand

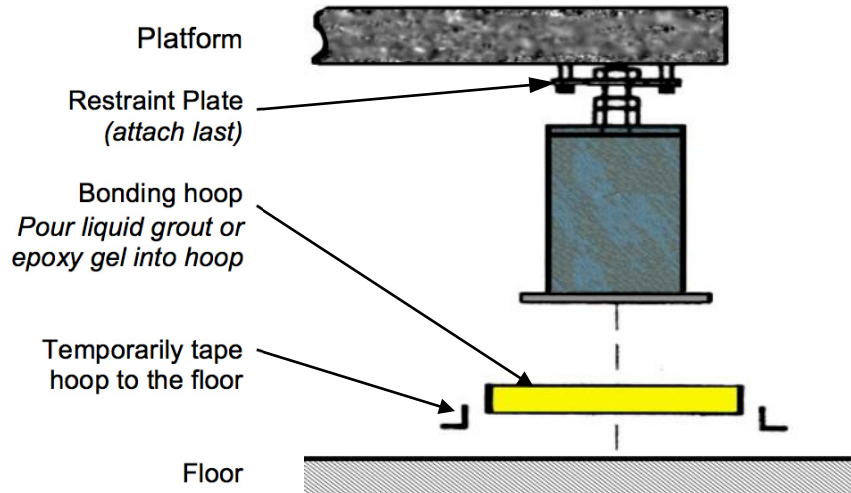

Figure 3, 8 x 8 Post leveling floor stand



**Note** Special arrangements of support stands may be documented with special instructions or drawings. Contact TMC if in doubt about the setup of your platform system.

## Stability

Best overall stability of the support system, and least amplification of vibration and structural modes, depends on a solid contact to the sub-floor under any baseplates or tripod feet.

It is recommended for all sensitive equipment installations, that a hard-setting grout be used under the baseplates of all support stands. A liquid type of grout may be poured into bonding hoops that surround each baseplate; or a thicker, gel type of epoxy grout may be put on the floor and the stand set on it.

Grout is only used for void filling and to give uniformity of support under the base. Anchoring the stands to the floor with bolts is more for security than for vibration control if the stands are grouted in places. When grout is used it should be allowed to cure undisturbed before tightening the anchor bolts.

## Tools Required

Excluding rigging equipment or anchor bolts.

- Long carpenters level
- **2-1/2 inch** adjustable or open-ended wrench, qty 2
- **15/16 inch** combination or adjustable wrench
- Epoxy type grout. water-mixed anchor-setting cement or other approved grout as required.

## Sub-floor Inspection and Preparation

- Check the surface of the concrete to make sure there are no breaks or irregularities in the areas where the stands will be seated.
- If the sub-floor is covered and sealed with a solid vinyl or similar floor covering, it may be left in place if it is solidly in contact with the concrete at each of the support feet.
- Again, inspect the surface and tap around in the area of contact to make sure there are no hidden voids or lumps under the floor covering.

Local areas should be cut away if there is a sub-surface problem.

## Floor Stand Positioning Instructions

### Tripod or Post Type

**Step 1** Place the tripod or post type floor stands in each of the general designated locations.

**Step 2** Place optional restraint plates on the jack screws of any floor supports that will be fastened to the platform.

**Step 3** Check the floor surface at each post location area and correct the surface as needed.

Most often a tripod can be rotated or repositioned slightly to avoid small local irregularities.

**Step 4** Place a mark on the floor for each floor stand bottom footplate location.

**Step 5** Place the appropriate size bonding hoop down on each marked floor location under each footplate.

**Step 6** Position each hoop so that the footplate is centered within the hoop with uniform clearance.



**Note** Supports at the platform restraint points must be within **1 inch** of the nominal locations in order to mate with tapped holes in the underside of the platform.

---

**Step 7** Place anchor bolts into the floor for attaching the floor stands.

You may also wait until the floor stand locations have been grouted before placing anchor bolts in the floor.



**Step 8** Add grout into the center of the hoop at each of the floor stand footplate locations as follows.

- Pick each of the floor stands up and move it out of position.
- Place a large blob of epoxy grout in the center of each footplate location or pour about **1/4 inch** of liquid cement grout into each hoop.
- Place the floor stand back into location, positioning each footplate over the grout.
- Allow the grout to cure before tightening the anchor bolts or placing the platform on top.

**Step 9** Tighten anchor bolts around each floor stand.

## Rigid Platform and Stand Systems

### Leveling Post and Rigid Post

- Raised floor heights: 6 inches to 24 inches
- Post heights: Variable

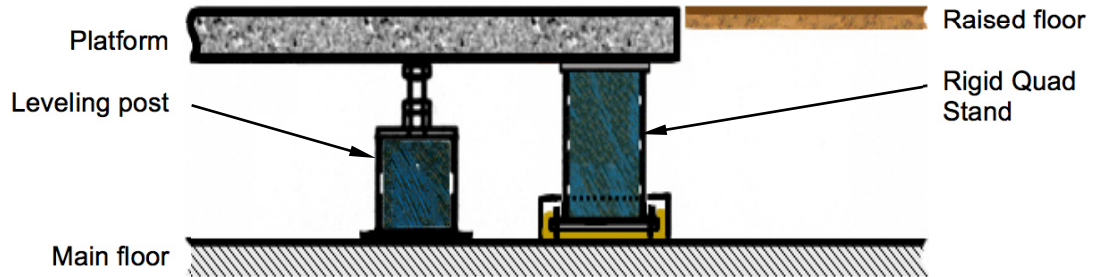

Figure 4, *Leveling Post and Rigid Post*

### Tripod Leveling Stand and Rigid Quad Stand and Leveling Post and Rigid Tripod Stand

- Raised floor heights: 18 inches to 24 inches
- Tripod Leveling Stand heights: 14 inches, 20 inches
- Rigid Quad Stand heights: 13 1/2 inches, 19 1/8 inches
- Leveling Post heights: Various
- Rigid Tripod Stand heights: 19 1/8 inches

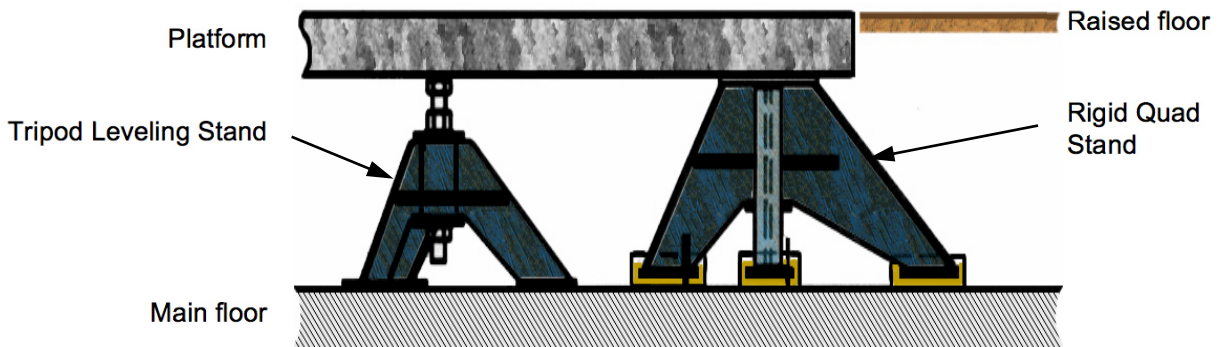

Figure 5, *Tripod Leveling Stand and Rigid Quad Stand*

### Rigid Quad Stand, Tripod Leveling Stand, Rigid Tripod Stand and Leveling Post

- Raised floor heights  
36 inches, 1 meter, 1.2 meter, 48 inches
- Rigid Quad Stand heights  
31-1/8 inches, 34-1/2 inches, 42 inches, 43 inches
- Rigid Tripod Stand heights  
43 inches
- Tripod Leveling Stand heights  
32 inches, 35-1/2 inches, 43 inches, 44 inches
- Leveling Post height: Various

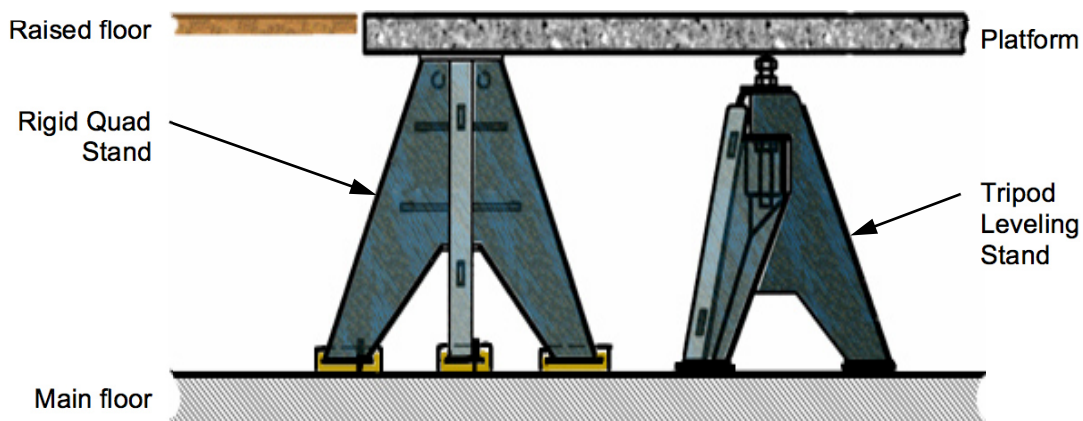

Figure 6, Rigid Quad Stand and Tripod Leveling Stand

## Platform Placement Instructions

- Step 1** Ensure that all anchor bolts used to secure floor stands to the floor are tightened securely.
- Step 2** Ensure that floor stands that will be secured to the platform have their restraint plates on the jack screws
- Step 3** Ensure that any floor stands located in the center of the platform or in the middle of the sides that will not be primary leveling points are turned down below the nominally correct height.
- Step 4** Lower the platform onto the floor stands.  
If the platform has to be repositioned a little, it is better to push it on rigging jacks then to slide it on the jack screws, which might damage threads or upset the stands if they are only grouted in position.

## Adjusting Floor Stands

The adjustment process is fundamentally one of changing from a 3-point support to a multi-point support with reasonably uniform loading.

The adjustment process minimizes bending distortions in the platform, thereby raising its modal frequency responses (and resultant stiffness) to maximum loads for the given stand locations.

Keep in mind that, even with the standard **1-1/2 - 6 UNC** threads of the jack stands, **1/16** turn is only about **.010 inch** change in height. The platform is stiff enough that over-driving the correct height position of any stand will start to lift the platform off nearby stands.

Using simple techniques, the stands will be adjusted to a high degree of accuracy.

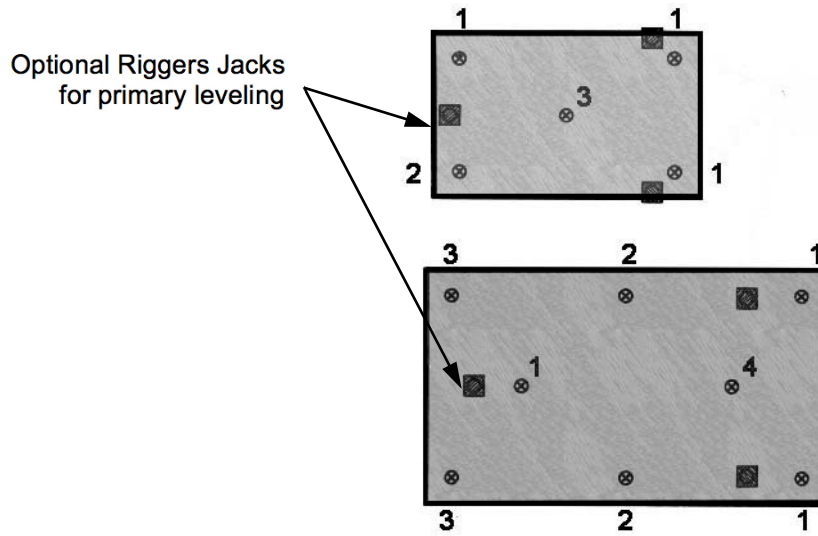

Figure 7, *Leveling Adjustment Sequence*

## Small Platform Floor Stand Adjustments

Platforms using 4-5 Floor Stand Supports

- Step 1** Turn down the jack screw of any floor stand support near the center of the platform so that it will not interfere with primary leveling.
- Step 2** Adjust the 4 corner stands to level the platform as needed relative to the surrounding floor and according to a carpenter's level.
- Step 3** Lock adjustment hard on 3 of the 4 corner floor stands as soon as a level position is found.
- Step 4** Fine adjust the 4th stand and any center stands according to the Fine Adjustment Steps listed in **Checking Floor Stand Adjustments** below.

## Large Platform Floor Stand Adjustments

Platforms using 6 or more Floor Stand Supports

It is best to start with a 3-point support for primary leveling, and easiest to do it if one support can be close to the centerline of the platform near one end, while two mounts at the corners of the opposite end complete the triangle.

- Step 1** Adjust the jack screws on the 3 primary floor stands for a level position and then lock position in place with jam nuts.
  
- Step 2** If there are 3 or more floor stands along the long sides of the platform, then adjust the jack screws up on those stands at the midpoint or closer to the single support end of the primary triangle.  

Tighten the jack screws with a fairly light torque against the platform initially, but don't lock the position with the jam nuts.
  
- Step 3** Adjust the jack screws up at the remaining corners to bring in firm contact with the platform
  
- Step 4** Adjust any remaining jack screws accordingly.

## Checking Floor Stand Adjustments

The objective is to have all of the floor stands bearing a uniform weight.

- The platform tops are stiff enough that once the floor stands are uniformly adjusted, any one of the stands can be released rather easily and abruptly.

This should be done as a test of adjustment, preferably for all of the floor stands that were not the first primary 3 stands adjusted.

As a floor stand is rechecked by the release-and-re-tighten method it may be locked securely.

- Another simple method to confirm best adjustment with a recheck is to thump firmly with a fist on the platform near the stand being adjusted.

As the best adjustment point is reached, the platform will sound "deader" and more tightly clamped.

- A more sophisticated method of monitoring the adjustments is to use a vibration analyzer (preferably 2 channels) with suitably sensitive accelerometers.
- Check to see that all of the lock nuts are secure.
- Bolt any restraint plates used on the underside of the platform. Keep the plates level against the underside of the screw drive nut while turning the **5/8 inch** bolts.

## Quiet Island: 67 Series with Gimbal Pistons

### Introduction

Raised Platform Isolators are generally used in raised floor environments, such as clean-rooms or computer floor labs, to isolate sensitive equipment from building vibrations.

They are built to the appropriate operating height to suit the floor height, and with a top platform size and shape suitable for the equipment to be isolated.

*Stability* Consideration is also given to stability. The platform may not be as small as the equipment footprint itself, if the vibration isolation mounts must be spread apart further to stabilize the payload. Often a heavy counterweight is used, bolted to and hanging from the underside of the platform top, to help to lower the center-of-gravity (c.g.) of the total payload.

Isolator mounts, platform top and counterweight, if required, are shipped as separate parts.

Refer to the drawing of the specific system to be installed for layout details.



**Caution** Ensure that the raised floor is rated for the load of the platform top and counter weight as they are transported to the site.

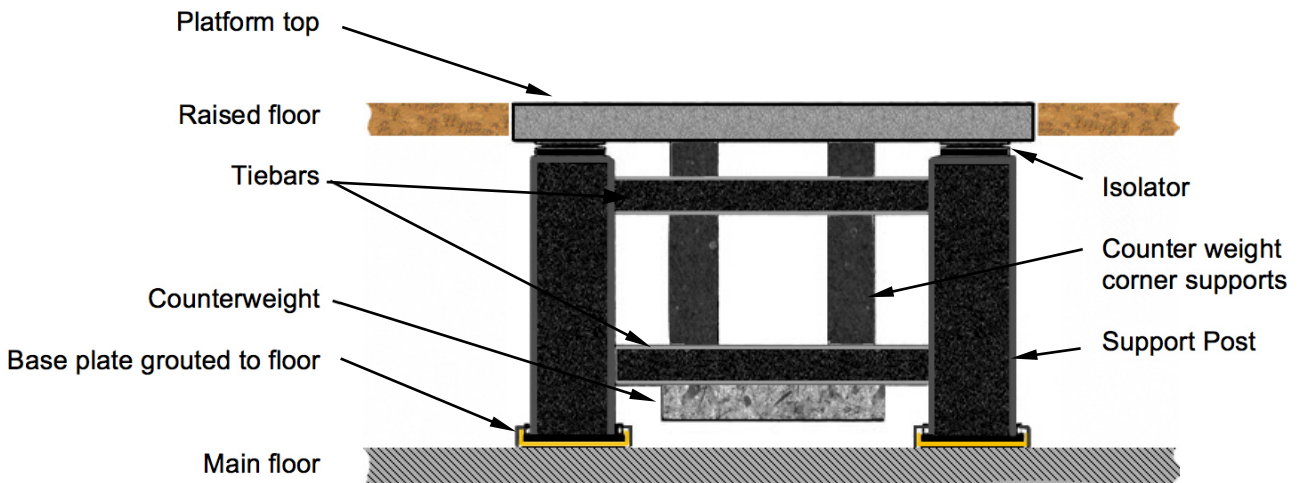

Figure 1, *Isolator platform side view layout*



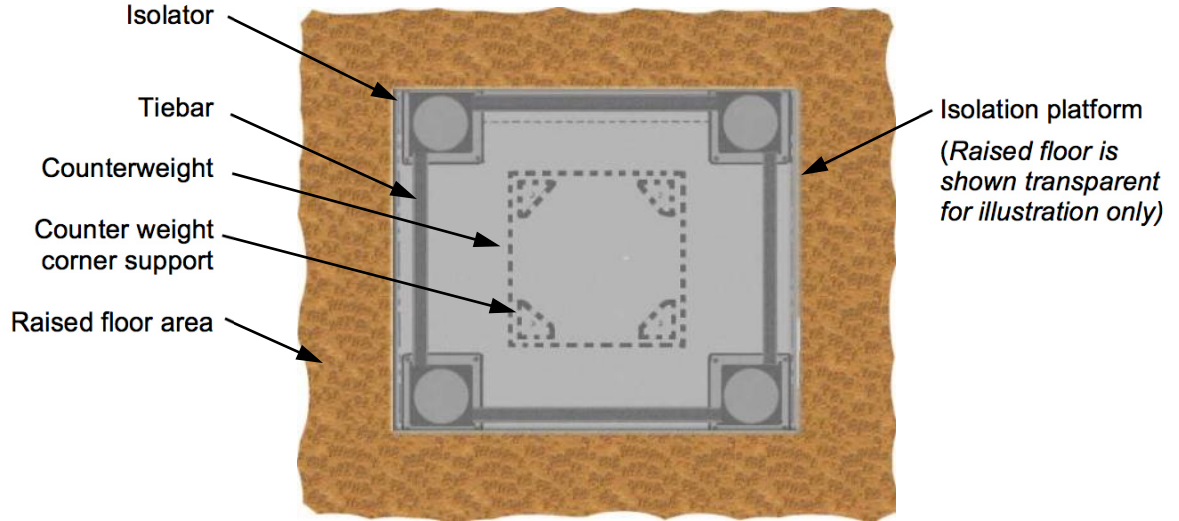

Figure 2, *Top view of Isolation platform*

## Floor Layout

Follow the system drawing and place the isolator frame or individual mounts in position in the floor, taking care to note locations of control valves if indicated.

The counterweight may be pre-assembled to the platform if it is not too large to handle, or it may be placed in the floor on spacer blocks and the platform lowered onto it.

Take note of any special orientations of the platform top and counterweight, as the counterweight may be off-set from center if it is also used to counter a significantly offset equipment payload.

## Isolator Assembly and Setup

- Step 1** Assemble tiebars to the isolators if supplied.  
Take note of the tiebar's length relative to the orientation of the top.
- Step 2** If the isolators were supplied with leveling baseplates, place the **2 x 2 inch** steel plates on the floor under the baseplate leveling screws
- Step 3** Turn down the screws just enough to engage the dimple in each plate.

### Air Supply Input Connection

**Step 4** Plumb tubing between air supply and system's input air filter as appropriate.

**Fittings** Tubing can be connected to a **1/4 or 1/8 inch NPT** female fitting as shown in figure below.

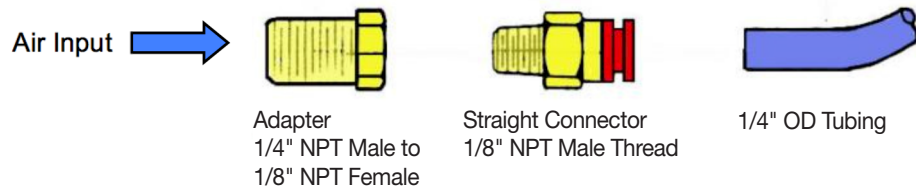

Figure 3, Air Supply Input Connection

### Internal Air Supply Tubing

**Step 5** Install air supply tubing between *air supply filter*, *isolators*, and *control valves* as appropriate.

- M** = Master Isolator with Height Control Valve (V)
- S** = Slave Isolator (no valve)

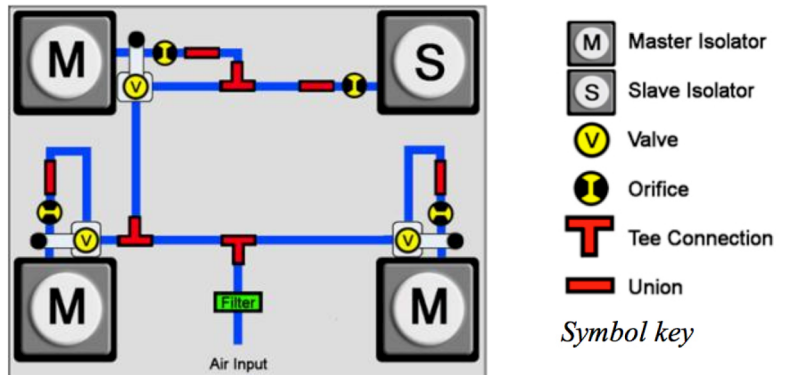

Figure 4, Typical valve schematic for a 4- isolator system

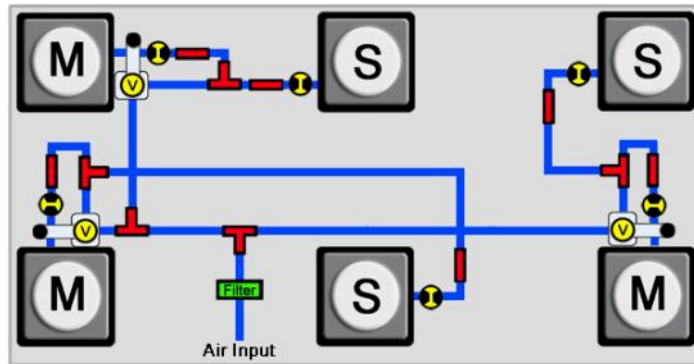

Figure 5, Typical valve schematic for a 6- isolator system

Ensure the slave isolator [S] is plumbed down-stream from its corresponding master isolator [M].

Optional self-sticking “J” clips are provided for neatly attaching the air hose to the tiebars.



**Note** Each post is shipped with a short section of tubing with a union coupler already attached to the input elbow.

This “pigtail” segment should not be tampered with. Each pigtail contains a small, flow-restricting orifice to damp table motion and stabilizes the load. A small red ring around the tube marks the orifice position.

If lost or damaged, please contact TMC for replacement pigtails.

**Connecting** Insert the air tube firmly into the self-sealing fitting as shown in figure below.

**Disconnecting** Push the red cylinder with your thumb and forefinger toward the center of the fitting body while pulling the tube in the opposite direction as shown in figure below.

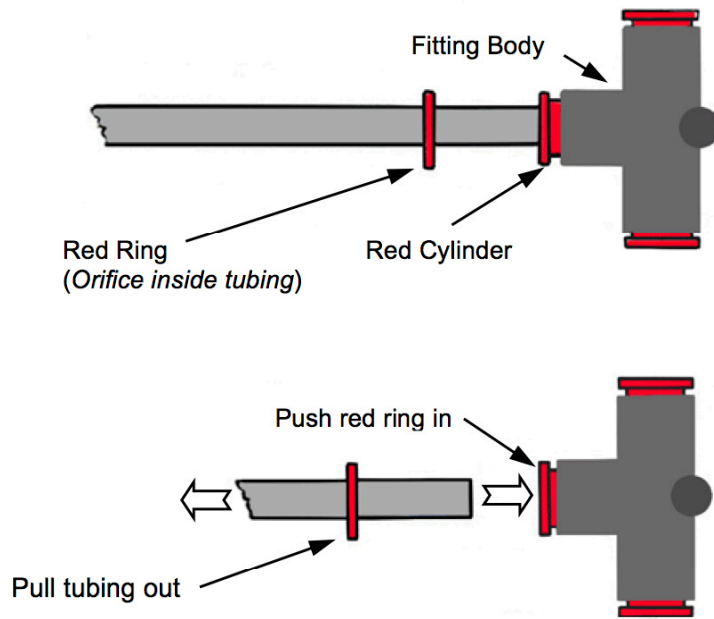

Figure 6, *Air tube connections*

**Orifices** Flow restricting orifices are critical to damping system motion. Orifices are located both inside the isolators and in the air tubing and marked by a red ring as shown in figure above.



**Important!** Do not remove or change the location of these orifices without first contacting TMC.

### **Platform Top and Counterweight Attachment**

**Step 6** Place the counterweight down on the main floor on spacer blocks.

It can also be pre-assembled to the top and lower the two together.

**Step 7** Place the counterweight in its correct position on blocks with its hanger bars just level or slightly above the tops of the isolators.

Leave the lower bolts on the hangers loose.

**Step 8** Lower the top into place

Keep most of the weight of the platform and counterweight supported by the rigging equipment until final positioning is complete.

**Step 9** Align the top bolt holes in the hangers to the holes in the top and loosely assemble them with the **5/8-11** bolt hardware supplied.

**Step 10** Tighten all of the counterweight bolts securely.

**Step 11** Center the platform top and counterweight assembly on the isolators and squared up to the floor tile pattern.

This operation may also require sliding the isolator mounts or complete frame around a little to keep the correct position.



**Note** Check whether special dimensions are given on the drawing.

---

**Step 12** Center the top piston plates.

**Step 13** Level up the whole isolation system to the raised floor height and check it with a carpenter's level.

Adjust all of the baseplate leveling screws to support the load equally — equal torque 'by feel' is adequate.

### Attach Horizontal Lever Arms

**Step 14** Locate the three height control valves mounted on isolators as typically shown in figure 4 & 5 earlier.

**Step 15** Ensure the main air supply is **Off**.

**Step 16** Adjust the **ISOLATOR HEIGHT ADJUST** screw CW (clockwise as viewed top down) to lower *foam pad* down to the lowest position close to the *horizontal lever arm* as referenced in figure below. Retract *locking nut* as required.

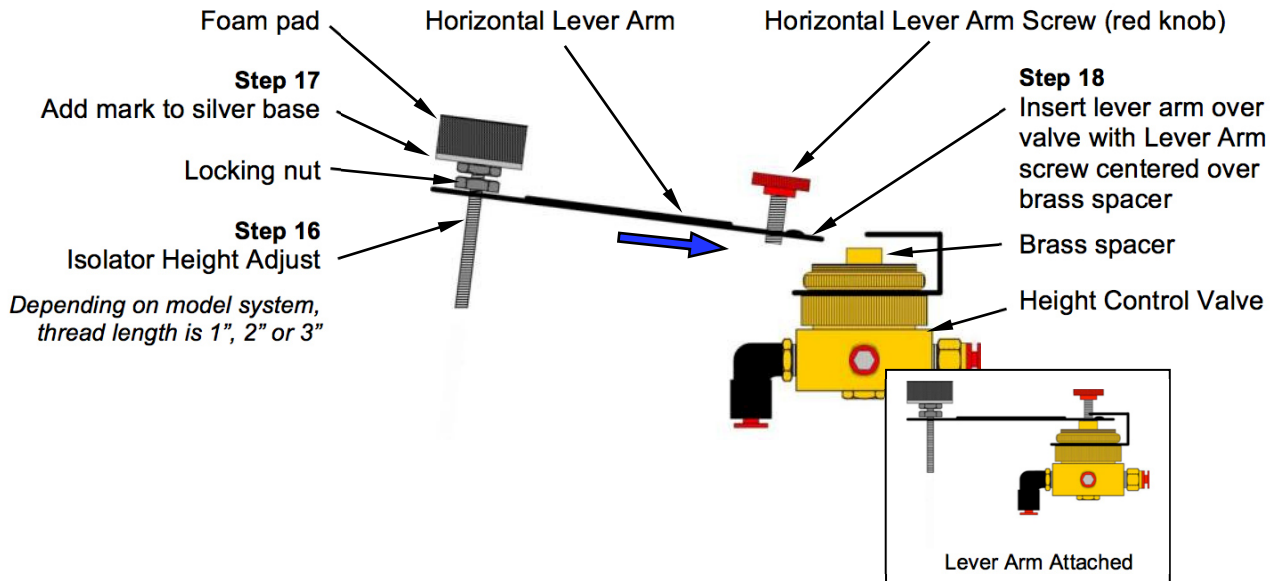

Figure 7, Attaching Horizontal Lever Arm

- Step 17** Using a marking pen, mark a spot on the edge of the *foam pad*'s silver colored base to later use as a rotation indicator for **ISOLATOR HEIGHT ADJUST**.
- Step 18** Insert *horizontal lever arm* onto *height control valve* ensuring the end of the **HORIZONTAL LEVER ARM SCREW** fits over the center of the *brass spacer*.
- Step 19** Loosely fasten *horizontal lever arm* with **HORIZONTAL LEVER ARM SCREW** (red knob) and adjust to position arm horizontally with valve.
- Step 20** Repeat above steps for attaching *horizontal lever arm* onto remaining two valves.

### Isolator Height Adjustment

- Step 21** Adjust the **ISOLATOR HEIGHT ADJUST** screw raising *foam pad* until it is in slight contact with the platform.

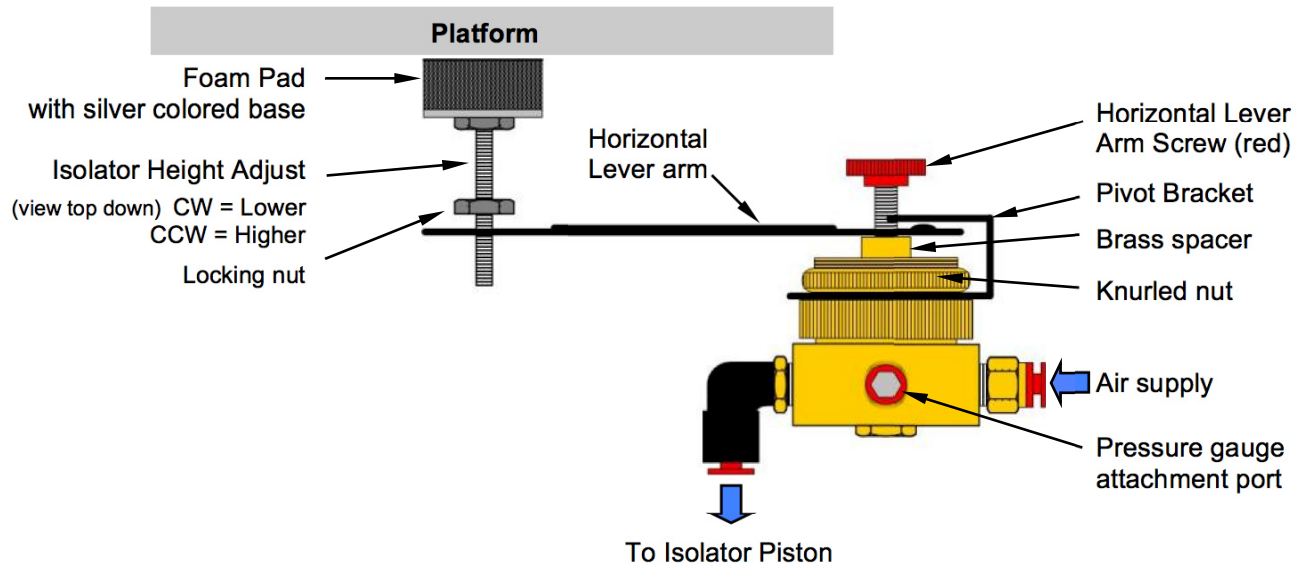

Figure 8, *Height Control Valve*

- Step 22** While observing spot marked on the base of the *foam pad* earlier, continue to adjust **ISOLATOR HEIGHT ADJUST** screw another **5 turns CCW**, or more depending on model system being applied to.

*The foam pad material will compress against tabletop.*

- Step 23** Repeat above steps for **ISOLATOR HEIGHT ADJUST** on remaining two isolators with a valve attached.

### **Gimbal Piston Adjustment**

- Step 24** Turn on the main air supply and set to **60-80 psi max.**

*After a short delay, all the load disks should lift away from the clamp rings and the tabletop will then be floating.*

- Step 25** Check to see that the top of the *piston* and the top surface of the *clamp ring* are parallel as shown in figure below.

Sliding or tapping *load disk* towards the low spot of the *piston* will correct any tilt.

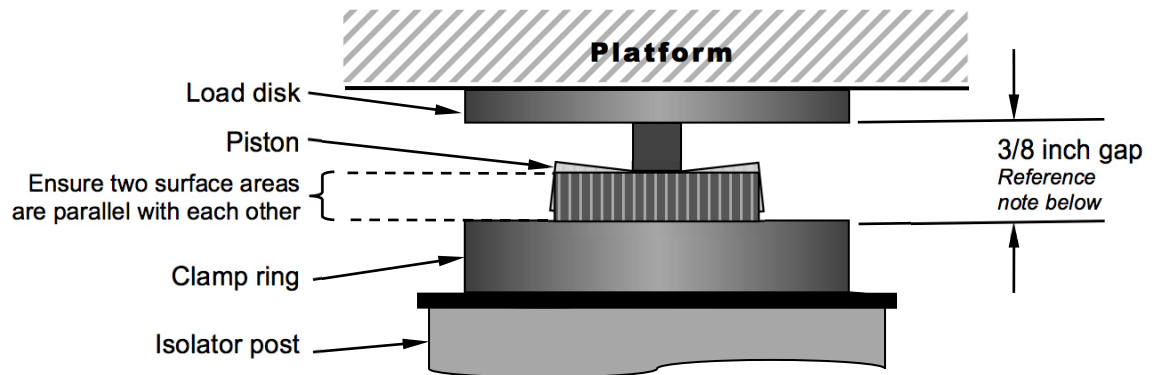

Figure 9, *Gimbal Piston*





**Note** Centering the Gimbal piston mechanism is important to achieve best horizontal isolation properties.

The mid-point of the vertical range should be determined by the gap between bottom surface of *load disk* and top surface of *clamp ring*.

Gap distance is as follows and referenced in figure above.

**4 x 4 inch** cross section: **3/8 inch** gap

**6 x 6** or **8 x 8 inch** cross section: **1/2 inch** gap

Some deviation from these heights may be necessary for proper leveling.

The platform should be free to move both vertically and horizontally. Any further leveling should only be done with the **ISOLATOR HEIGHT ADJUST** screw.

**Step 26** Tighten *locking nut* on all three **ISOLATOR HEIGHT ADJUSTS** as shown in figure 8 above, *Height Control Valve*.



**Note** There will be some slight settling and improvement in the valve's height sensitivity within the first few days of operation. Again adjust **ISOLATOR HEIGHT ADJUST** if required.

### Adjust Air Pressure

**Step 27** Adjust the regulated air pressure down to **15–20 psi** above the highest pressure reading of the three pressure gauges. This will optimize damping control of coarse disturbances.



**Note** Reducing the supply pressure differential will minimize the prolonged disturbance effects of sudden payload forces.

The valves must maintain a positive supply differential or air will be exhausted and the system will deflate.

Air flow through the valves is buffered with controls built into the isolators. If the main air supply pressure is not regulated, the detrimental effects may not be too severe.

## Final Stabilization

- Check system and ensure the top platform is positioned as it should be with respect to the tile floor.
- Ensure the isolators are leveled so that they support the top without rocking with the air off.
- Add additional stability and better overall isolation performance by grouting footplates with a liquid cement grout.

TMC can provide 'Bonding Hoops' for placing around the footplates (square containment dams) for this purpose.



TMC–Ametek  
15 Centennial Drive, Peabody MA 01960 USA  
Tel (800) 542-9725, (978) 532-6330 ▪ Fax (978) 531-8682  
tmc.sales@ametek.com ▪ tmc.ervice@ametek.com  
www.techmfg.com

All data in this document is subject to change in accordance with  
TMC–Ametek policy of continual product improvement.

Copyright © 2017 TMC–Ametek ▪ All Rights Reserved  
All registered marks and trademarks are property of their respective holders.